

TRT™ MK5 Specifications

Features and Benefits

The TRT™ (Trac Rail Transposer) is a rubber tracked machine designed to remove and install all rail sections including but not limited to bull head, flat bottom rail and conductor rail.

The TRT™ can be used to re-position any length of plain line rail from 20ft (6m) up to 1418ft (432m) and can also be utilised to transport, remove and install any length of S&C associated iron work such as switches and crossings.

- Proven **ultra reliable** during **15 years** of operation.
- Approved to work under live **Overhead Line Equipment (OLE)**, **Any Line Open working (ALO)**, and Catenary.
- Removes, transposes, moves, and installs rail in a **safe, controlled, manner by remote control**.
- Ideal for use on both **single line and multiple line layouts**.
- Can **easily cross multiple tracks**, including areas with conductor rails, without fear of damaging the rail.
- Capable of threading rail past line side equipment and masts without fear of damage.
- Operates equally well in **confined spaces like tunnels and bridges**, where right-of-way is at a premium
- **Compact size** and **maneuverability** allows rapid deployment and recovery.
- Its low gross weight means **no Commercial Driver's License** is needed for transportation.

Fig. 01

TRT™ in operation, threading length of rail directly into sleeper housings.



Fig. 02

TRT™'s travelling with section of switch and crossing.



TRT™ MK5 Specifications

Machine Data	Imperial	Metric
Vehicle Height	65.25 in	1661 mm
Vehicle Width	68.5 in	1742 mm
Vehicle Length	83.75 in	2129 mm
Between Tracks	48.75 in	1242 mm
Inside Clearance	39.5 in	1008 mm
Main Ram Travel	15.75 in	400 mm
Ram Side Shift	+/- 6 in	+/- 150 mm
Vehicle Speed	1.6 mph (@ 2,300rpm)	2.6 km/h (@ 2,300rpm)
Gradient	11 deg (1:5, 20%) Gradient, 20 deg (36.4%) Cross Slope	
Vehicle Tare Weight	3241 lbs	1470 kg
Lifting Capacity	6614 lbs	3 t
Vibration (Hand)	N/A (Remote Controlled)	
Noise Levels (High Engine Speed)	Sound Pressure Level @ 1m:LpA 86.7 dB(A) Sound Power Level: LwA 97.7 dB(A)	

Engine Data	Imperial	Metric
Engine	Kubota - 05 Series V1505-E4B, 4 Cylinder	
Emissions	EPA/CARB Tier 4	EU Stage V
Power	25 bhp @ 2,300 rpm	18.5 kW @ 2,300 rpm
Idle Speed	1150 rpm	
Max No Load Speed	2400 rpm	
Alternator	12 volt, 40 amp, 480 watt	
Battery	Type 027 - 12V, 60 Ah, 540 CCA	
Oil Type	SAE 15W-40	
Oil Capacity	1.75 US gallon	6.7 Litre
Coolant	Glycol 50% / 50% Water	
Coolant Capacity	1 US gallon	4 Litre
Fuel Type	Diesel	
Fuel Tank Capacity	7.75 US gallon	30 Litre

Hydraulic Data	Imperial	Metric
System Relief Pressure	2610 psi	180 Bar
Track Motor	Single Displacement Speed Setting	
Parking Brake	Spring Applied Hydraulically Released, 1 per track, within Gearbox	
Oil Type	DIN 51524-2 Category HLP - ISO VG 32	
Tank Capacity	6.5 US gallon	25 Litres
Pump - 26.2 cc/rev	15 gallon/min @ 2,300 rpm	57.2 Litres/min @ 2,300 rpm
Plough Connection	Quick Release Connections - 5 L/min (1.25 US gal/min) spool	
Auxiliary Connection	Quick Release Connections - 28.6 L/min (7.5 US gal/min) @ idle, selected via Aux Switch 11 on the PCU	
Recovery Circuit	Quick Couplings for Recovery Engine, Return @ Tank, Feed @ Pump Outlet	

Electrical Parameter	Imperial	Metric
Remote Control	Light weight, weather & impact resistant - Control of machine functions: 5 (of 6) Levers for proportional control and switches for ON/OFF control.	
Receiver Unit	Relay of the Remote's signals to the hydraulic control valve block and the Machine Display. Integral LEDs and a Code Display for Real-Time Status.	
Machine Display	Engine Status & Operations Request Interface	
Emergency Stops	2, Located Front and Rear - Stops the Engine & Immobilises the machine	
Remote's Isolator Button	Central Red button on the Remote - Immobilises the machine	
Battery Isolator	Isolates the machine's battery	
PCU Battery Charger	Charges the Spare PCU Battery while the Machine is On	
Work Lights	4 LED Lights - There's a Switch On Sequence From one when Isolator is Switched On to all four illuminated once the Remote is Paired	
HALO Lights	4 Lights forming a HALO around the machine - On/Off Switch on the Remote	
Signal Horn	Horn operated from the Remote	
Beacon	Illuminates at the same time as the HALO lights	
Aux/USB Sockets	Input: 12V, Outputs: 1x 5V 3A USB, 1x USB-C, 1x 12V 15A Lighter Style Power Socket	

Dimensions

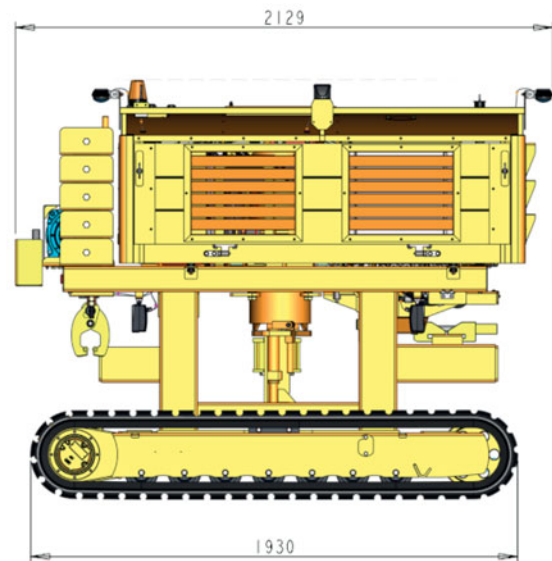
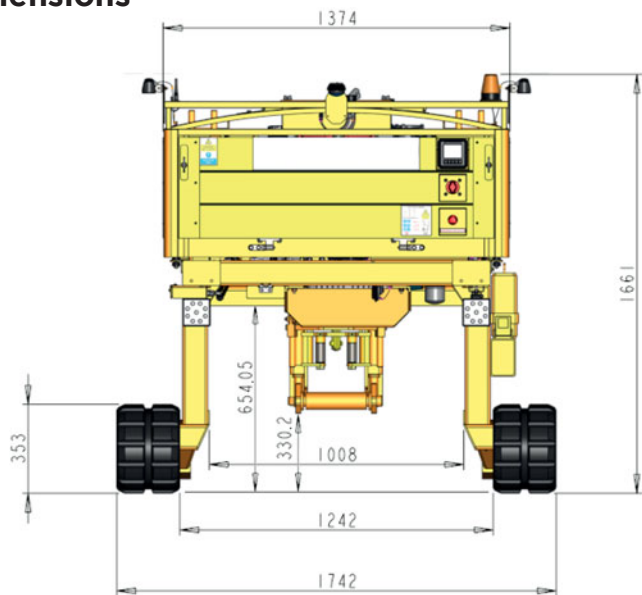

Attachments

We have a wide range of complimentary accessories for the TRT™ which reduce the number of additional tools and equipment required on site.

Recovery engine

This engine enables completion of the task and recovery of the vehicle from track locations.

Plough

Clears most ballast from either side of the track, on the sleeper ends.

Hydraulic tools

Versatile front-mounted connectors that power various hydraulic tools such as rail drills, impact wrenches and profile grinders.

TRT™ mounted jib

The jib attachment allows safe lifting of track furniture up to 990kgs in live OLE areas.

Switches & crossings

Unique S&C handling heads can move switches and crossings safely, from access to install.

Rail saw

A zero-emission, hydraulic, long arm saw designed to allow full use in a standing position, reducing fatigue and the risk of back injury.

Other accessories are available, please contact us for more information on the full range.

Fig. 03

TRT Ballast Plough.



Fig. 04

TRT Rail Cutting Saw.



Fig. 05

TRT Jib Crane.

